



HFNS SERIES NUT SPLITTER

Tackle tough jobs even in tight corners with our sleek nut splitters. Crack through even the most stubborn rusted nuts with our powerful hydraulic cylinder, ensuring effortless splitting. Built to last, our one-piece cutting frame and heavy-duty construction mean you can depend on these splitters for years to come. Our specially angled cutter blade with radius resists wear and tear, ensuring long-lasting performance. Choose the perfect splitter for your needs with our variety of sizes available.

- Compact design used in confined space with enough force to split the rusted nuts.
- All models feature a rugged one-piece cutting frame coupled to heavy-duty hydraulic cylinder.
- Specially designed "tool steel" cutter blade cuts the nut to the precise point where it cracks.
- Unique angled head design to keep full contact with the nut being penetrated.
- Unique angled cutter blade with radius to have the greater resistance to cutting and breaking nuts.
- 5 popular models applicable to cover the most range of nuts.



Heavy-Duty Hydraulic Cylinder

10-50 TON Capacity

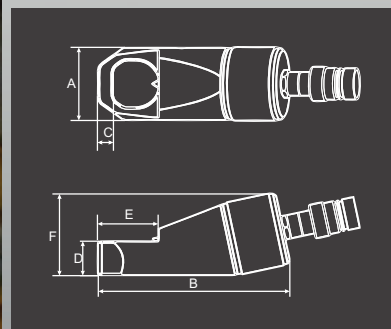

MODEL	HEXAGON NUT RANGE (mm)	BOLT RANGE (mm)	CAPACITY (TON)	OIL CAPACITY (c.c.)	A (mm)	B (mm)	C (mm)	D (mm)	E (mm)	F (mm)	WEIGHT (Kg)
HFNS-1924	19-24	M12-M16	10	18	60	171.5	10	25	40	68	2.2
HFNS-2432	24-32	M16-M22	15	40	70	192	13	30	52	79	3.3
HFNS-3241	32-41	M22-M27	20	68	80	230	16	36	65	92	4.4
HFNS-4150	41-50	M27-M33	35	150	100	286	21	45	76	116	8.2
HFNS-5060	50-60	M33-M39	50	250	117	321	24	54.5	92	134	11.7

*The hardness of nut material must not exceed HRC-44. Should not be used on stainless steel nuts and/or square shape nuts.